



# Drafting II All Models & Sizes

Specification Sheet



**TAA**  
COMPLIANT

DRAFTING II SPEC SHEET v4.4 / U.S. Patent No. 10225509 / EFFECTIVE 4/24/2026  
*Specifications are subject to change without notice.*

The Drafting II is a complete, ruggedized multitouch table available with 43", 49", 55", or 65" displays. There is also a 55" option for an optically bonded display. It features a fixed, ergonomically angled LG 4K UHD display with industry-leading touch technology from TES and Displax. The Drafting II is equipped with a powerful integrated Intel™ Core processor, the latest NVIDIA™ discrete graphics card, and push-button power.



The Drafting II touch table comes standard with Windows 11 Pro and can run any supported PC applications. The Drafting II can also be purchased with an AOPEN Commercial Chromebox 3 rated for 24/7 use. This table is often used as kiosk in public settings or with AEC (architecture engineering & construction) applications. The Drafting II multitouch table is constructed from aircraft-grade aluminum and covered with a durable powder coat.

The thin profile computer case inside the pedestal base allows for a full-sized graphics card, and the enclosure makes the unit incredibly quiet. The all-aluminum construction and additional fans provide additional active cooling in a modular design. *(The photo below shows the internal components.)*

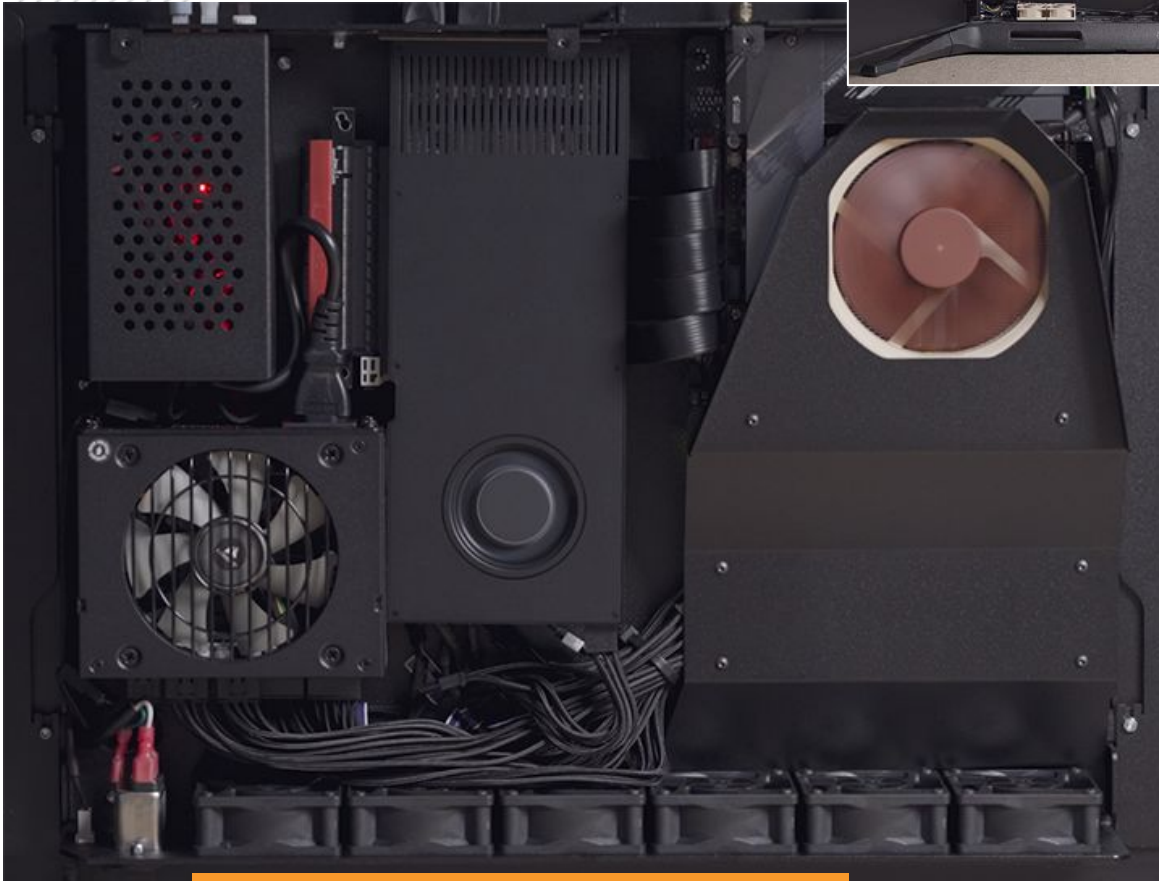
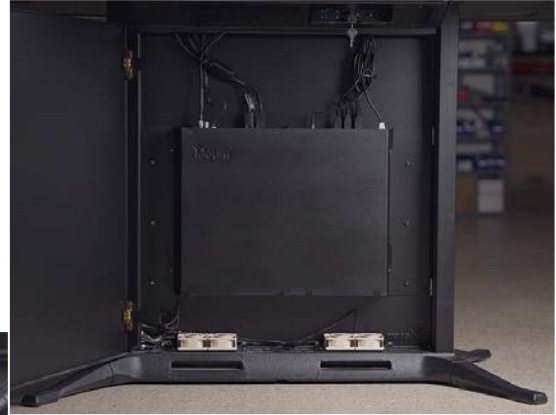

Ideum displays use a patented manufacturing method. The Drafting II is built in the USA and ships as a complete turnkey system with lockable, push-button operation. It doesn't require a technician or any special installation setup—just plug it in and turn it on. All of Ideum's hardware is backed by a three-year warranty.

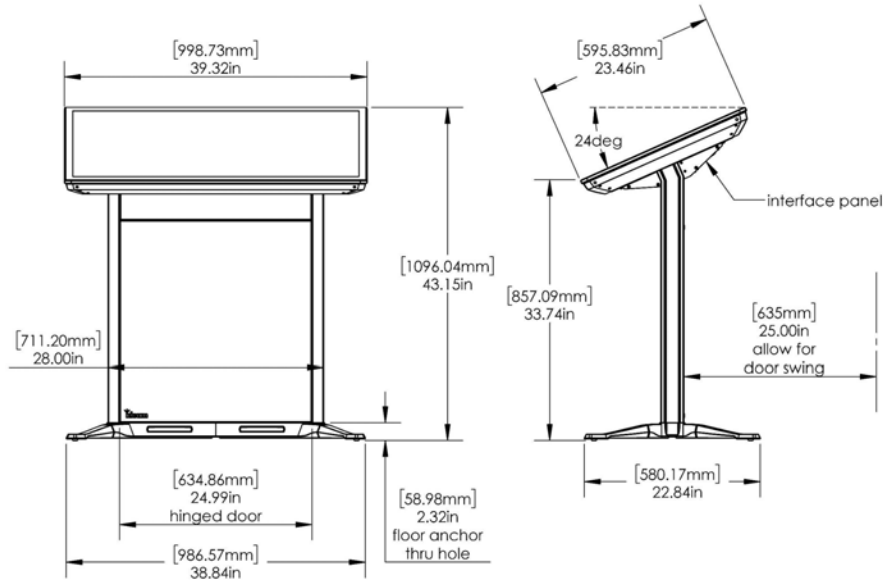

**WEIGHT**  
145 LBS  
66 KG

**SHIP WEIGHT**  
280 LBS  
127 KG

**WITH TRAVEL CASE**  
385 LBS  
175 KG

### Interactive Display

- › 4K UHD (3840x2160) LG commercial display rated 24/7
- › 43" diagonal, strengthened, anti-stiction, 4mm glass surface
- › TES /3M™ projected capacitive touch sensor
- › ±5 ms touch response time
- › 80 touch points with palm rejection
- › Native contrast ratio 1100:1
- › 500 nits luminance

### Integrated System

	STANDARD	PERFORMANCE	ULTIMATE
› Push-button power			
› Lockable enclosure			
› Windows 11 Professional	› Intel 15th Gen Core Ultra 5	› Intel 15th Gen Core	› Intel 15th Gen Core
› Universal 110-240V power system	245K processor	Ultra 7 265K processor	Ultra 9 285K processor
› (2) 10W Integrated speakers	› NVIDIA RTX A2000 Ada	› NVIDIA RTX 4000 Ada	› NVIDIA GeForce RTX
	Generation 16GB graphics card	Generation 20GB graphics card	5080 16GB graphics card
	› 500GB M.2 NVMe SSD	› Dual 500GB M.2 NVMe SSD	› 2TB M.2 NVMe SSD
	› 16GB DDR5 RAM	› 32GB DDR5 RAM	› 64GB DDR5 RAM

### Connectivity

- › TPM/TPP compatible for secure environments
- › WiFi 802.11 a/b/g/n/ac, Ethernet, Bluetooth 5.0
- › Wireless keyboard with integrated trackpad
- › Direct access via USB ports
- › Audio output via 1/8" audio jack
- › HDMI output (PC)
- › RFID (optional)
- › Communication hardware can be removed upon request for secure environments

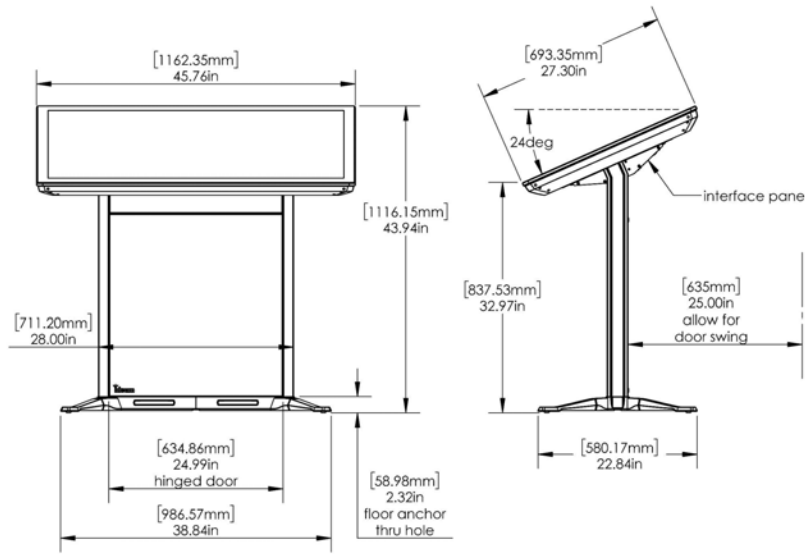

**WEIGHT**  
155 LBS  
71 KG

**SHIP WEIGHT**  
320 LBS  
146 KG

**WITH TRAVEL CASE**  
390 LBS  
177 KG

### Interactive Display

- › 4K UHD (3840x2160) LG commercial display rated 24/7
- › 49" diagonal, strengthened, anti-stiction, 4mm glass surface
- › TES /3M™ projected capacitive touch sensor
- › ±5 ms touch response time
- › 80 touch points with palm rejection
- › Native contrast ratio 1100:1
- › 500 nits luminance

### Integrated System

- › Push-button power
- › Lockable enclosure
- › Windows 11 Professional
- › Universal 110-240V power system
- › (2) 10W Integrated speakers

#### STANDARD

- › Intel 15th Gen Core Ultra 5 245K processor
- › NVIDIA RTX A2000 Ada Generation 16GB graphics card
- › 500GB M.2 NVMe SSD
- › 16GB DDR5 RAM

#### PERFORMANCE

- › Intel 15th Gen Core Ultra 7 265K processor
- › NVIDIA RTX 4000 Ada Generation 20GB graphics card
- › Dual 500GB M.2 NVMe SSD
- › 32GB DDR5 RAM

#### ULTIMATE

- › Intel 15th Gen Core Ultra 9 285K processor
- › NVIDIA GeForce RTX 5080 16GB graphics card
- › 2TB M.2 NVMe SSD
- › 64GB DDR5 RAM

### Connectivity

- › TPM/TPP compatible for secure environments
- › WiFi 802.11 a/b/g/n/ac, Ethernet, Bluetooth 5.0
- › Wireless keyboard with integrated trackpad
- › Direct access via USB ports
- › Audio output via 1/8" audio jack
- › HDMI output (PC)
- › RFID (optional)
- › Communication hardware can be removed upon request for secure environments

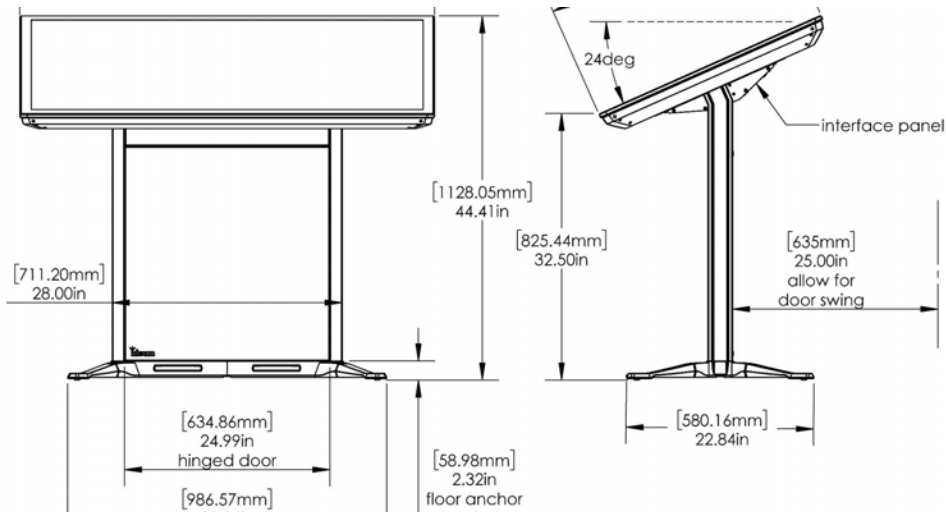

**WEIGHT**  
170 LBS  
78 KG

**SHIP WEIGHT**  
345 LBS  
157 KG

**WITH TRAVEL CASE**  
410 LBS  
186 KG

### Interactive Display

- › 4K UHD (3840x2160) LG commercial display rated 24/7
- › 55" diagonal, strengthened, anti-stiction, 4mm glass surface
- › TES /3M™ projected capacitive touch sensor
- › ±5 ms touch response time
- › 80 touch points with palm rejection
- › Native contrast ratio 1100:1
- › 500 nits luminance

### Integrated System

	STANDARD	PERFORMANCE	ULTIMATE
› Push-button power			
› Lockable enclosure			
› Windows 11 Professional	› Intel 15th Gen Core Ultra 5	› Intel 15th Gen Core	› Intel 15th Gen Core
› Universal 110-240V power system	245K processor	Ultra 7 265K processor	Ultra 9 285K processor
› (2) 10W Integrated speakers	› NVIDIA RTX A2000 Ada	› NVIDIA RTX 4000 Ada	› NVIDIA GeForce RTX
	Generation 16GB graphics card	Generation 20GB graphics card	5080 16GB graphics card
	› 500GB M.2 NVMe SSD	› Dual 500GB M.2 NVMe SSD	› 2TB M.2 NVMe SSD
	› 16GB DDR5 RAM	› 32GB DDR5 RAM	› 64GB DDR5 RAM

### Connectivity

- › TPM/TPP compatible for secure environments
- › WiFi 802.11 a/b/g/n/ac, Ethernet, Bluetooth 5.0
- › Wireless keyboard with integrated trackpad
- › Direct access via USB ports
- › Audio output via 1/8" audio jack
- › HDMI output (PC)
- › RFID (optional)
- › Communication hardware can be removed upon request for secure environments

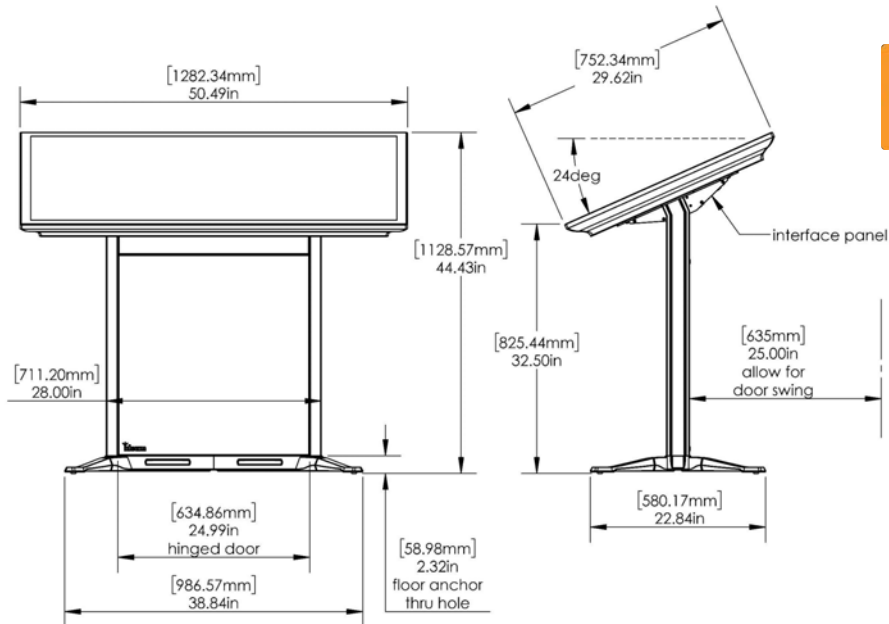
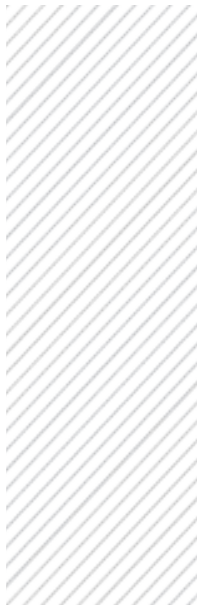

### Interactive Display



**WEIGHT**  
175 LBS  
79 KG\*

**SHIP WEIGHT**  
350 LBS  
159 KG\*

**WITH TRAVEL CASE**  
415 LBS  
188 KG\*

- › 4K UHD (3840x2160) LG commercial display rated 24/7
- › 55" diagonal, strengthened, anti-stiction, 4mm glass surface
- › Optically bonded sensor and LCD
- › TES /3M™ projected capacitive touch sensor
- › ±5 ms touch response time
- › 80 touch points with palm rejection
- › Native contrast ratio 1100:1
- › 500 nits luminance

## Integrated System

<ul style="list-style-type: none"> <li>› Push-button power</li> <li>› Lockable enclosure</li> <li>› Windows 11 Professional</li> <li>› Universal 110-240V power system</li> <li>› (2) 10W Integrated speakers</li> </ul>	<p><b>STANDARD</b></p> <ul style="list-style-type: none"> <li>› Intel 15th Gen Core Ultra 5 245K processor</li> <li>› NVIDIA RTX A2000 Ada Generation 16GB graphics card</li> <li>› 500GB M.2 NVMe SSD</li> <li>› 16GB DDR5 RAM</li> </ul>	<p><b>PERFORMANCE</b></p> <ul style="list-style-type: none"> <li>› Intel 15th Gen Core Ultra 7 265K processor</li> <li>› NVIDIA RTX 4000 Ada Generation 20GB graphics card</li> <li>› Dual 500GB M.2 NVMe SSD</li> <li>› 32GB DDR5 RAM</li> </ul>	<p><b>ULTIMATE</b></p> <ul style="list-style-type: none"> <li>› Intel 15th Gen Core Ultra 9 285K processor</li> <li>› NVIDIA GeForce RTX 5080 16GB graphics card</li> <li>› 2TB M.2 NVMe SSD</li> <li>› 64GB DDR5 RAM</li> </ul>
--	--	---	--

## Connectivity

- › TPM/TPP compatible for secure environments
- › WiFi 802.11 a/b/g/n/ac, Ethernet, Bluetooth 5.0
- › Wireless keyboard with integrated trackpad
- › Direct access via USB ports
- › Audio output via 1/8" audio jack
- › HDMI output (PC)
- › RFID (optional)
- › Communication hardware can be removed upon request for secure environments

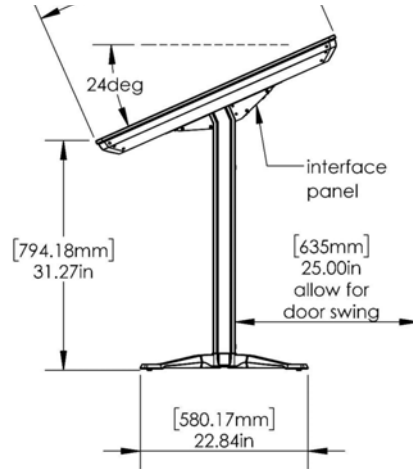
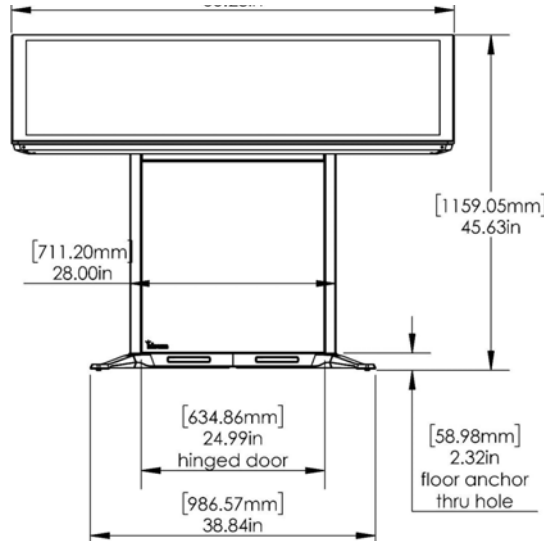

**WEIGHT**  
205 LBS  
93 KG

**SHIP WEIGHT**  
385 LBS  
175 KG

**WITH TRAVEL CASE**  
492 LBS  
224 KG

### Interactive Display

- › 4K UHD (3840x2160) LG commercial display rated 24/7
- › 65" diagonal, strengthened, anti-stiction, 4mm glass surface
- › Display projected capacitive touch sensor
- › ±5ms touch response time
- › 40 touch points with palm rejection
- › Native contrast ratio 1100:1
- › 500 nits luminance

### Integrated System

	STANDARD	PERFORMANCE	ULTIMATE
› Push-button power			
› Lockable enclosure			
› Windows 11 Professional	› Intel 15th Gen Core Ultra 5 245K processor	› Intel 15th Gen Core Ultra 7 265K processor	› Intel 15th Gen Core Ultra 9 285K processor
› Universal 110-240V power system	› NVIDIA RTX A2000 Ada Generation 16GB graphics card	› NVIDIA RTX 4000 Ada Generation 20GB graphics card	› NVIDIA GeForce RTX 5080 16GB graphics card
› (2) 10W Integrated speakers	› 500GB M.2 NVMe SSD	› Dual 500GB M.2 NVMe SSD	› 2TB M.2 NVMe SSD
	› 16GB DDR5 RAM	› 32GB DDR5 RAM	› 64GB DDR5 RAM

### Connectivity

- › TPM/TPP compatible for secure environments
- › WiFi 802.11 a/b/g/n/ac, Ethernet, Bluetooth 5.0
- › Wireless keyboard with integrated trackpad
- › Direct access via USB ports
- › Audio output via 1/8" audio jack
- › HDMI output (PC)
- › RFID (optional)
- › Communication hardware can be removed upon request for secure environments

## Customizations



### Built-in Casters

Low profile built-in casters make it easy to move.



### Adjustable Keyboard Tray

Removable keyboard and mouse tray. Includes keyboard and mouse.



### Second Monitor

Multitouch 22" HD monitor with articulating mount.



### AEC Bundle

Casters, Keyboard Tray, and Second Monitor.



### Ultimate Upgrade

- > Intel 15th Gen Core Ultra 9 285K processor
- > NVIDIA GeForce RTX 5080 16GB graphics card
- > 2TB M.2 NVMe SSD
- > 64GB DDR5 RAM



### Chromebox System

Replaces the PC with an AOPEN Chromebox Commercial 3 rated 24/7. Not available with the Optically Bonded display.



### Colors and Finishes

Available in hundreds of RAL color and finish options.



### ATA Flight Case

Reusable travel case with locking casters and locking latch clasps.

### What's Inside

Our touch tables include the best performing, most reliable components available.

4K UHD (3840x2160) commercial LCD display

PCAP touch sensor with 80 touch points TES (3M) technology

NVIDIA™ graphics card

Intel® Core™ Processor

Aircraft-grade aluminum made in the USA



## Software



The Drafting II touch table comes with Windows 11 Pro and supports PC applications. Applications that are optimized for touch work best.

Ideum offers custom software development. We have experience developing interactive applications, mostly for public spaces. Our expertise in a broad range of programming environments allows our work to span the realms of informal and formal education, interactive technology, art, and entertainment.

### ALSO AVAILABLE



#### RFID Utility

**Ideum multitouch products include an optional RFID utility for enhanced functionality.**

Our new and improved RFID software allows you to automate system tasks, launch and switch applications, and more with a single movement. This useful utility is free for Ideum touch table owners.

Learn more at: [ideum.com/news/rfid-reader-app](https://ideum.com/news/rfid-reader-app)



# Drafting II

Specification Sheet

## About Ideum

Ideum designs experiences for public spaces, offering exhibit design, AV, and software development services to museums, nonprofits, and socially responsible companies. We are proudly based in Corrales, New Mexico, and collaborate with creative partners worldwide.

### SALES & DESIGN INQUIRIES

We sell our multitouch tables and displays directly, both in the USA and internationally. Ask us how to turn your interactive goals into amazing reality.

Use our [online inquiry form](#)  
Email: [sales@ideum.com](mailto:sales@ideum.com)  
Phone: (505) 792-1110 ext. 1

### WARRANTY & SUPPORT

Our products are custom-built with only the highest quality components available and are designed to last. We back all of our hardware, including custom exhibits, with a three-year warranty. The same people who design and build our systems provide our timely support.

Submit a ticket: [support.ideum.com](https://support.ideum.com)  
Email: [support@ideum.com](mailto:support@ideum.com)  
Phone: (505) 792-1110 ext. 2

**Hours: 8:00 AM – 5:00 PM Mountain Time, Monday through Friday.**

The Colossus, Drafting, Pano, Platform, Pico, Pro, Reader Rail, and Inline touch tables and the Portrait and Presenter touch displays from Ideum are designed, manufactured, and made in the USA of U.S. and imported parts.



Compliant with height and reach requirements for the Americans with Disabilities Act standards for accessibility. Learn more about Ideum's commitment to accessibility at [www.ideum.com/ada](http://www.ideum.com/ada)

*IMPORTANT NOTICE TO PURCHASER: Specifications are subject to change without notice. Ideum hardware and software are warrantied from the date of receipt to the period stated in the warranty. Please note that under Ideum's warranty, Ideum has no obligation for any hardware product that is modified or damaged through misuse, accident, neglect, or subsequent integration, service, or tampering, by anyone other than Ideum or an Ideum-approved entity or individual. Ideum makes no additional warranties, express or implied, including but not limited to any fitness for a particular purpose. The User is responsible for determining whether Ideum hardware products or software are fit for the User's particular purpose. If the hardware product or software are proven not to have met Ideum's warranty, then Ideum's sole obligation and User's and Purchaser's exclusive remedy will be, at Ideum's option, to repair or replace the product or refund its purchase price. Ideum shall not be liable in any action against it in any way related to the hardware products or software for any loss or damages, whether non-specified, direct, indirect, special, incidental or consequential (including downtime, loss of profits or goodwill) regardless of the legal theory asserted. Please see our full warranty for complete details.*

