



Pico 43", 49"

Specification Sheet



PICO SPEC SHEET v3.8/ U.S. Patent No. 10225509 / EFFECTIVE 4/1/2026
Specifications are subject to change without notice.

The Pico is a fully integrated multitouch coffee table available with 43" and 49" displays. It includes a 4K Ultra HD LG commercial display rated 24/7 and industry-leading touch technology from TES (formerly 3M™) with support for 80 simultaneous touch points. The Pico can support tangible interaction.



The Pico comes complete with a full-featured and powerful integrated Intel® Core™ processor, the latest NVIDIA™ discrete graphics card, and single push-button power. It comes standard with Windows 11 Professional and can run any supported PC applications. The Pico can also be purchased with an AOPEN Commercial Chromebox rated for 24/7 use.

The thin profile computer case inside the pedestal base allows for a full-sized graphics card, and the enclosure makes the unit incredibly quiet. The all-aluminum construction and additional fans provide active cooling in a modular design. *(The photo below shows the internal components.)*

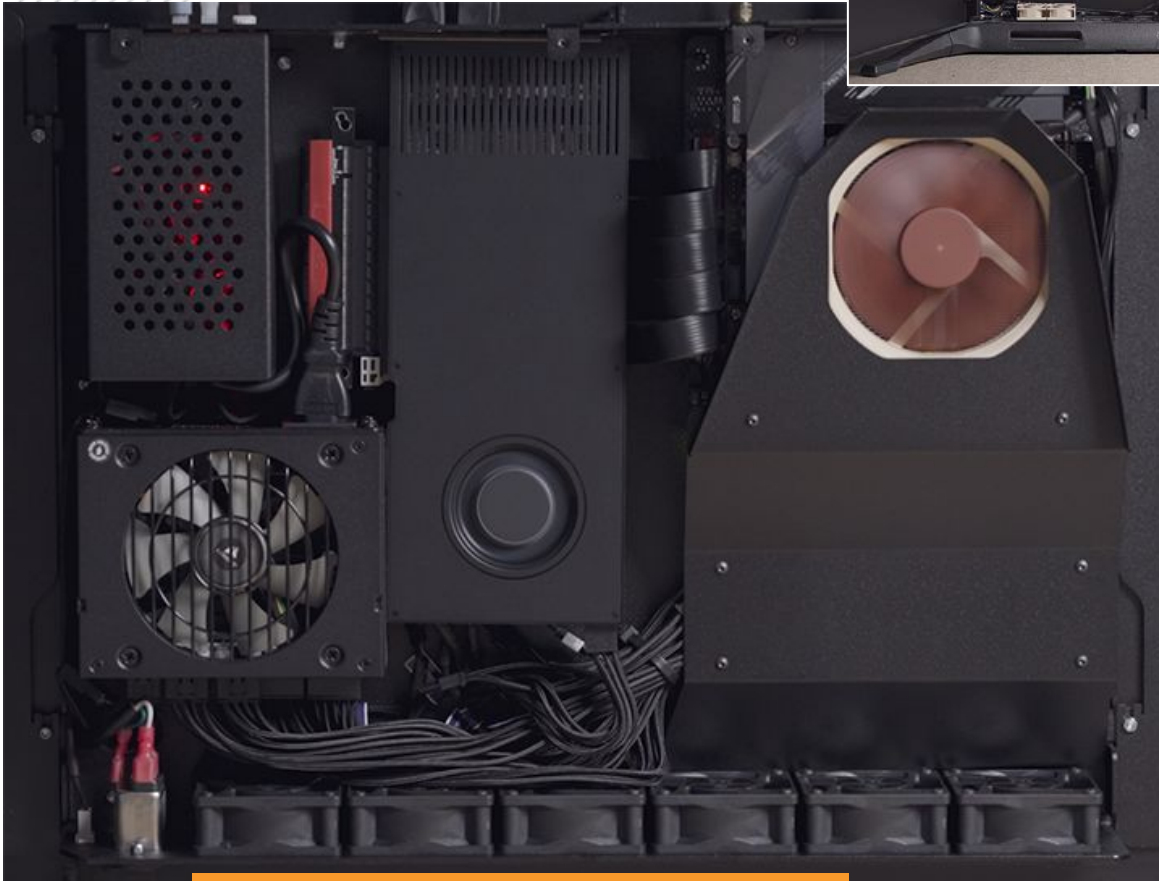

Ideum displays use a patented manufacturing method.

The Pico is built in the USA and ships as a complete turnkey system with lockable, push-button operation. It doesn't require a technician or any special installation setup—just plug it in and turn it on. All of Ideum's hardware is backed by a three-year warranty.

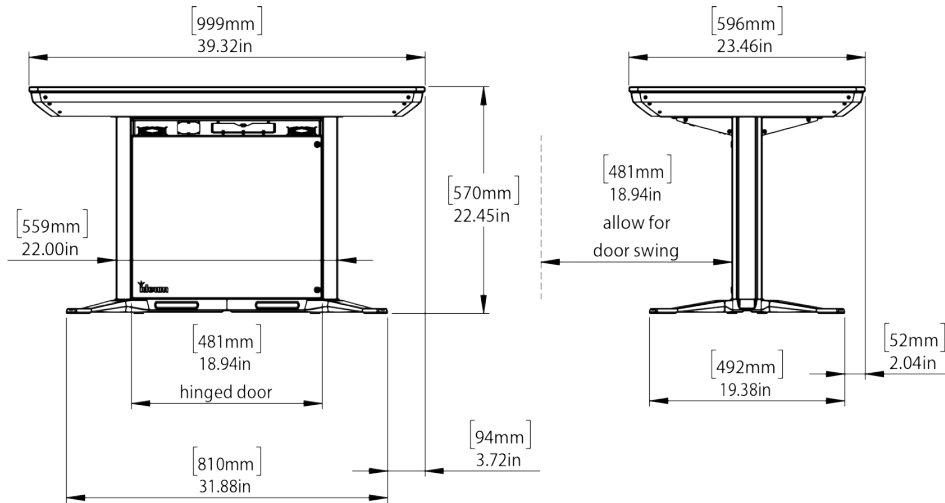

WEIGHT 113 LBS 51 KG*
SHIP WEIGHT 213 LBS 97 KG*
WITH TRAVEL CASE 283 LBS 128 KG*

*Weights may vary slightly.

Interactive Display

- › 4K UHD (3840x2160) LG commercial display rated 24/7
- › 43" diagonal, strengthened, anti-stiction, 4mm glass surface
- › TES /3M™ projected capacitive touch sensor
- › ±5 ms touch response time
- › 80 touch points with palm rejection
- › Native contrast ratio 1100:1
- › 500 nits luminance

Integrated System

- › Single push-button power
- › Custom lockable enclosure
- › Windows 11 Professional
- › Universal 110-240V power system
- › Two 10W integrated speakers

STANDARD

- › Intel 15th Gen Core Ultra 5 245K processor
- › NVIDIA RTX A2000 Ada Generation 16GB graphics card
- › 16GB DDR5 RAM
- › 500GB M.2 NVMe SSD

PERFORMANCE

- › Intel 15th Gen Core Ultra 7 265K processor
- › NVIDIA RTX 4000 20GB Ada Generation graphics card
- › 32GB DDR5 RAM
- › Dual 500GB M.2 NVMe SSD

Connectivity

- › TPM/TPP compatible for secure environments
- › WiFi 802.11 a/b/g/n/ac, Ethernet, Bluetooth 5.0
- › Wireless keyboard with integrated trackpad
- › Direct access via USB ports
- › Audio output via 1/8" audio jack
- › HDMI output (PC)
- › RFID (optional)
- › Communication hardware can be removed upon request for secure environments

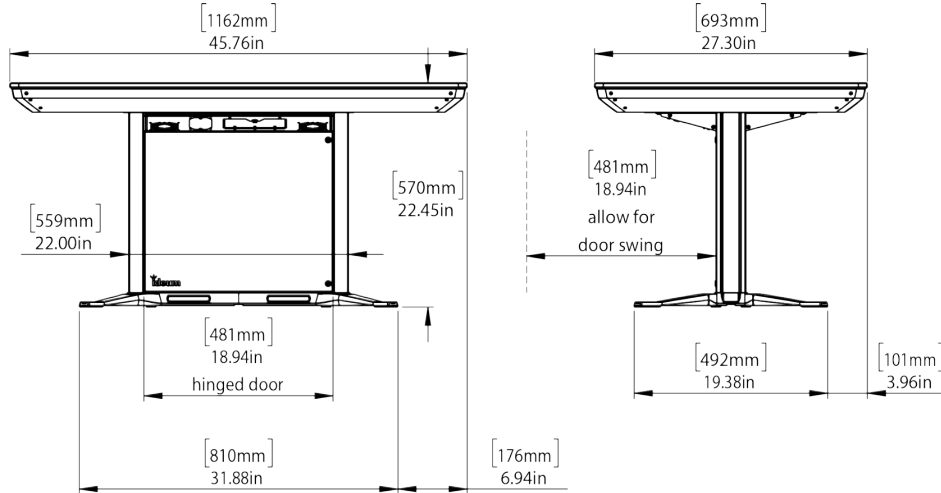

WEIGHT 130 LBS 59 KG*
SHIP WEIGHT 230 LBS 104 KG*
WITH TRAVEL CASE 300 LBS 136 KG*

*Weights may vary slightly.

Interactive Display

- › 4K UHD (3840x2160) LG commercial display rated 24/7
- › 49" diagonal, strengthened, anti-stiction, 4mm glass surface
- › TES /3M™ projected capacitive touch sensor
- › ±5 ms touch response time
- › 80 touch points with palm rejection
- › Native contrast ratio 1100:1
- › 500 nits luminance

Integrated System

- › Single push-button power
- › Custom lockable enclosure
- › Windows 11 Professional
- › Universal 110-240V power system
- › Two 10W integrated speakers

STANDARD

- › Intel 15th Gen Core Ultra 5 245K processor
- › NVIDIA RTX A2000 Ada Generation 16GB graphics card
- › 16GB DDR5 RAM
- › 500GB M.2 NVMe SSD

PERFORMANCE

- › Intel 15th Gen Core Ultra 7 265K processor
- › NVIDIA RTX 4000 20GB Ada Generation graphics card
- › 32GB DDR5 RAM
- › Dual 500GB M.2 NVMe SSD

Connectivity

- › TPM/TPP compatible for secure environments
- › WiFi 802.11 a/b/g/n/ac, Ethernet, Bluetooth 5.0
- › Wireless keyboard with integrated trackpad
- › Direct access via USB ports
- › Audio output via 1/8" audio jack
- › HDMI output (PC)
- › RFID (optional)
- › Communication hardware can be removed upon request for secure environments

Customizations



Colors and Finishes

Available in hundreds of RAL color and finish options. (1-2 weeks additional lead time.)



ATA Flight Case

Reusable travel case with locking casters and locking latch clasps.



Chromebox System

Replaces the PC with an AOPEN Chromebox Commercial 3 rated 24/7.

What's Inside

Our touch tables and touch walls include the best performing, most reliable components available.

4K UHD (3840x2160)
commercial LCD
display

PCAP touch sensor
with 80 touch points
TES (3M) technology

NVIDIA™
graphics card

Intel® Core™ Processor

Aircraft-grade
aluminum made in
the USA



Software



The Pico touch table comes with Windows 11 Professional and supports PC applications. Applications that are optimized for touch work best.

Ideum offers custom software development. We have experience developing interactive applications mostly for public spaces. Our expertise in a broad range of programming environments allows our work to span the realms of informal and formal education, interactive technology, art, and entertainment.

ALSO AVAILABLE



Tangible Authoring

Ideum multitouch tables support the Tangible Engine object recognition SDK.

Tangible Engine is an authoring environment supporting the use of fiducial object recognition on Ideum multitouch tables. This software allows for the unique recognition of objects with 3D printed conductive patterns. Tangible Engine 3 includes test objects, a Visualizer / Configurator Tool, an SDK, and documentation.

Pricing and more information can be found at: tangibleengine.com



RFID Utility

Ideum multitouch products include an optional RFID utility for enhanced functionality.

Our new and improved RFID software allows you to automate system tasks, launch and switch applications, and more with a single movement. This useful utility is free for Ideum touch table owners.

Learn more at: ideum.com/news/rfid-reader-app

About Ideum

Ideum designs experiences for public spaces, offering exhibit design, AV, and software development services to museums, nonprofits, and socially responsible companies. We are proudly based in Corrales, New Mexico, and collaborate with creative partners worldwide.

SALES & DESIGN INQUIRIES

We sell our multitouch tables and displays directly, both in the USA and internationally. Ask us how to turn your interactive goals into amazing reality.

Use our [online inquiry form](#)

Email: sales@ideum.com

Phone: (505) 792-1110 ext. 1

WARRANTY & SUPPORT

Our products are custom-built with only the highest quality components available and are designed to last. We back all of our hardware, including custom exhibits, with a three-year warranty. The same people who design and build our systems provide our timely support.

Submit a ticket: support.ideum.com

Email: support@ideum.com

Phone: (505) 792-1110 ext. 2

Hours: 8:00 AM – 5:00 PM Mountain Time, Monday through Friday.

The Colossus, Drafting, Pano, Platform, Pico, Pro, Reader Rail, and Inline touch tables and the Portrait and Presenter touch displays from Ideum are designed, manufactured, and made in the USA of U.S. and imported parts.



Compliant with height and reach requirements for the Americans with Disabilities Act standards for accessibility. Learn more about Ideum's commitment to accessibility at www.ideum.com/ada

IMPORTANT NOTICE TO PURCHASER: Specifications are subject to change without notice. Ideum hardware and software are warranted from the date of receipt to the period stated in the warranty. Please note that under Ideum's warranty, Ideum has no obligation for any hardware product that is modified or damaged through misuse, accident, neglect, or subsequent integration, service, or tampering, by anyone other than Ideum or an Ideum-approved entity or individual. Ideum makes no additional warranties, express or implied, including but not limited to any fitness for a particular purpose. The User is responsible for determining whether Ideum hardware products or software are fit for the User's particular purpose. If the hardware product or software are proven not to have met Ideum's warranty, then Ideum's sole obligation and User's and Purchaser's exclusive remedy will be, at Ideum's option, to repair or replace the product or refund its purchase price. Ideum shall not be liable in any action against it in any way related to the hardware products or software for any loss or damages, whether non-specified, direct, indirect, special, incidental or consequential (including downtime, loss of profits or goodwill) regardless of the legal theory asserted. Please see our full warranty for complete details.